



MB 501D

Water-cooled MIG Gun

Designed for Industrial Durability



www.binzel-abicor.com

Table of Contents

MB501D Series, Water-Cooled MIG Guns w/Ratings	3
MB501D Series, Cable Assembly/Rear Ends.....	4
MB501D Series, Ordering Instructions	5
MB501D Consumables: Diffusers/Tip Holders	6
MB501D Series, Swannecks	6
MB501D Consumables: Nozzles.....	7
MB501D Consumables: Contact Tips	7
MB501D Consumables: Liners	8
MB501D MIG Gun Parts - Handles.....	9
MB501D MIG Gun Parts - List Body-Cable Assembly	10
MB501D MIG Gun Parts - Cable Assembly Enlargement.....	Inside back cover
Safety Information	Inside back cover

Available in:
EZGR
ERGO - Ergonomic (shown)

Water-Cooled cable efficiently cools front end for reduced heat and operator comfort

Chrome nozzle seat improves wear on swanneck and prolongs torch life

Quality consumable tips and nozzles for longer parts life.



Easy Grip with Extended Trigger Handle



Easy Grip Handle



Ergonomic Handle



Swannecks on 50° & 60°
Standard
Short
+2. +3. +4

Durable yet lightweight torch ideal for high amperages

Technical Data

MB501D

Rating: 500 Amp CO₂
450 Amp Mixed Gases
100% Duty Cycle
Wire Sizes: .035"-.078" (0.9mm-2.0mm)
Weight: 69 oz.

Rated using power source with VDE standard volt/amp characteristic $V=(Ax0.05) = 14$ When pulse welding, reduce rating by 35%

MB501D Series Water-Cooled MIG Guns

MB501D Rear Ends

- Standard with Euro-Quick direct connect rear end
- Available rear connectors for major wire-feed manufactures

Tweco 4



Lincoln



Lincoln 10



Miller



Euro



Ordering Information

MB Series MIG Torches are available in various configurations based on neck length, wire size, cable length and rear end connection. Refer to the detailed instruction below to determine the part number that best suits your requirements. If you have any questions, please contact Customer Service at 1.800.542.4867.

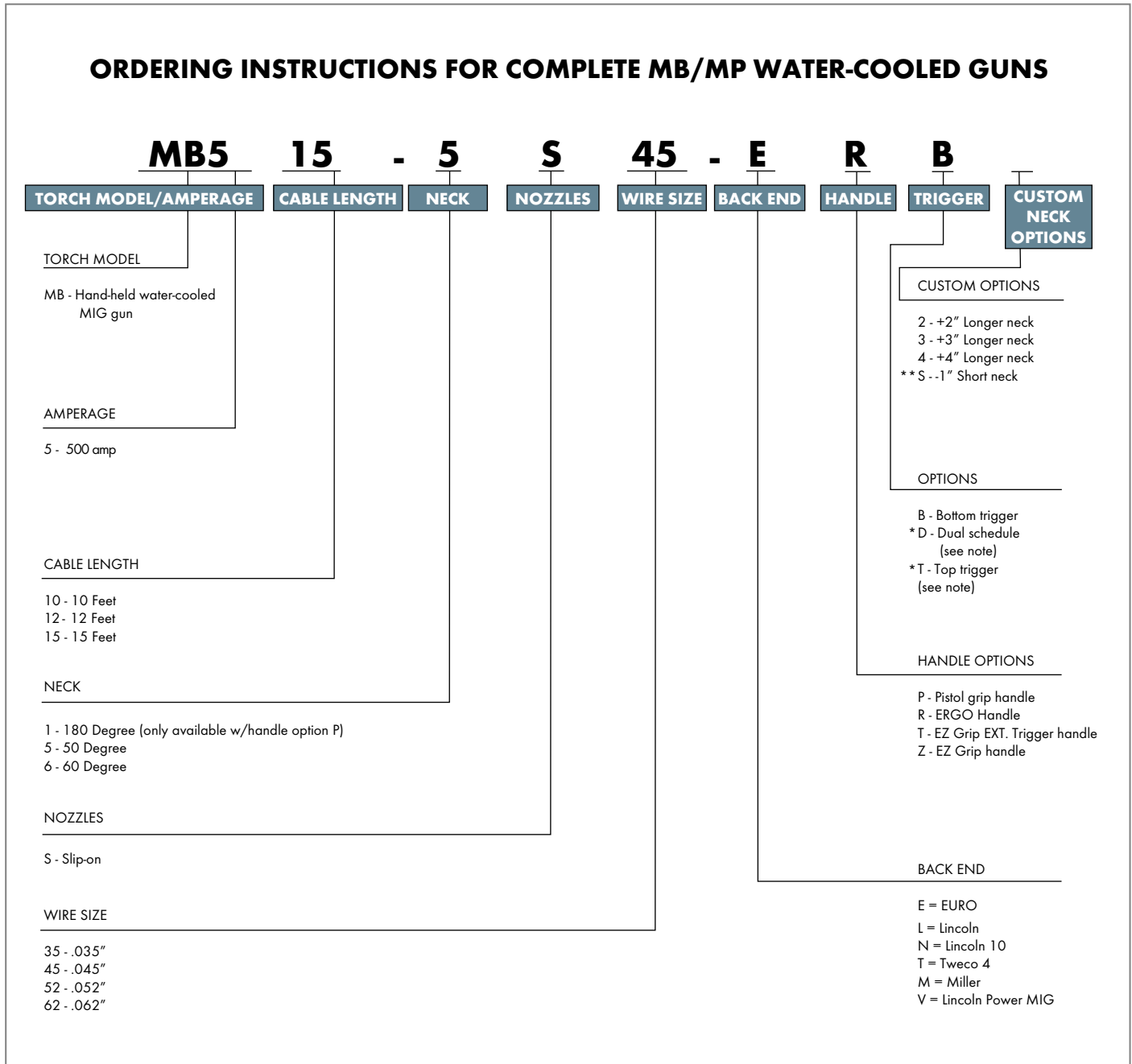

* Note: Dual Schedule or Top triggers only available on handle option "T" (extended trigger handle).

** Note: Not available with handle option "P"

MB 501 D Water-Cooled MIG Guns

Consumables: Diffusers, Tip Holders, and Swannecks

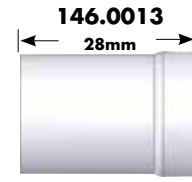

Diffusers/Insulators

Description	Part No.
Diffuser STD	030.0145
Diffuser Hi-Temp	030.0037
Insulator Nozzle	146.0013

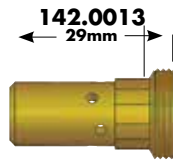

Tip Holder

Description	Part No.
Tip Holder M6 Spray Arc 501	142.0008
Tip Holder M6 Short Arc 501	142.0013
Tip Holder M8 Spray Arc 501	142.0022
Tip Holder M8 Short Arc 501	142.0027
Tip Holder M6 Short Arc 501 for Narrow Gap Pipe Nozzle	142.9058.US

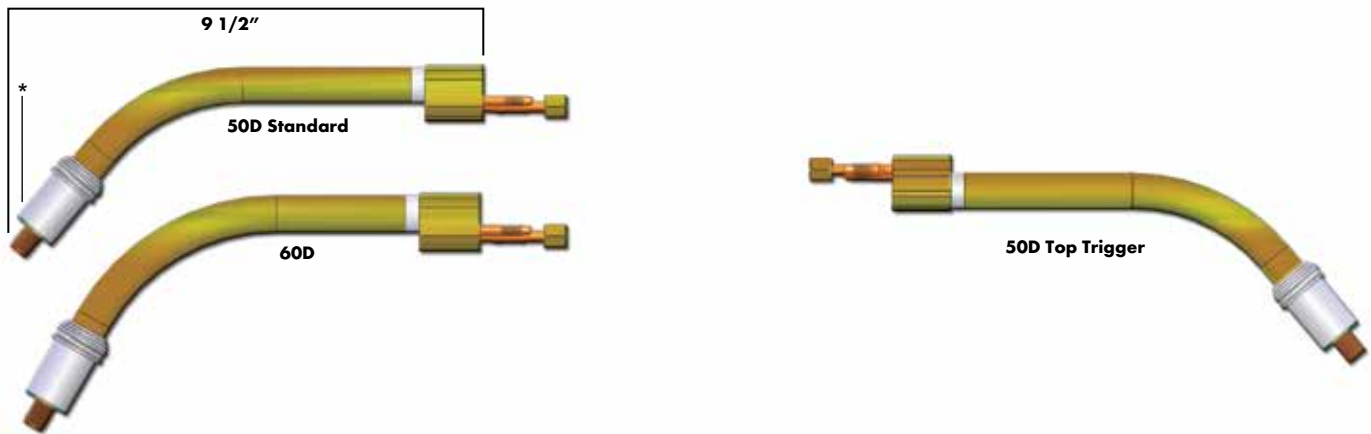

Swannecks MB501D 50 Degree and 60 Degree

Description	Part No.	Description	Part No.
Bottom Triggers		Bottom Triggers Short 1"	
Swanneck MB501D 50° Standard	034.0251	Swanneck MB501D 50° Short	033.0140
Swanneck MB501D 50° (+2 inches)	034.9440.US	Swanneck MB501D 60° Short	033.0290
Swanneck MB501D 50° (+3 inches)	034.9438.US	Top Triggers	
Swanneck MB501D 50° (+4 inches)	034.9435	Swanneck MB501D - Tight Tolerance 50°	034.0263
Swanneck MB501D 60° Standard	034.0511	Swanneck MB501D - Tight Tolerance 60°	034.0525
Swanneck MB501D 60° (+2 inches)	034.9441.US	Top Trigger Short 1"	
Swanneck MB501D 60° (+3 inches)	034.9439.US	Swanneck MB501D - TT 50° Short	033.0144
Swanneck MB501D 60° (+4 inches)	034.9437.US	Insulating Washer	030.0019

Consumables: Nozzles and Contact Tips

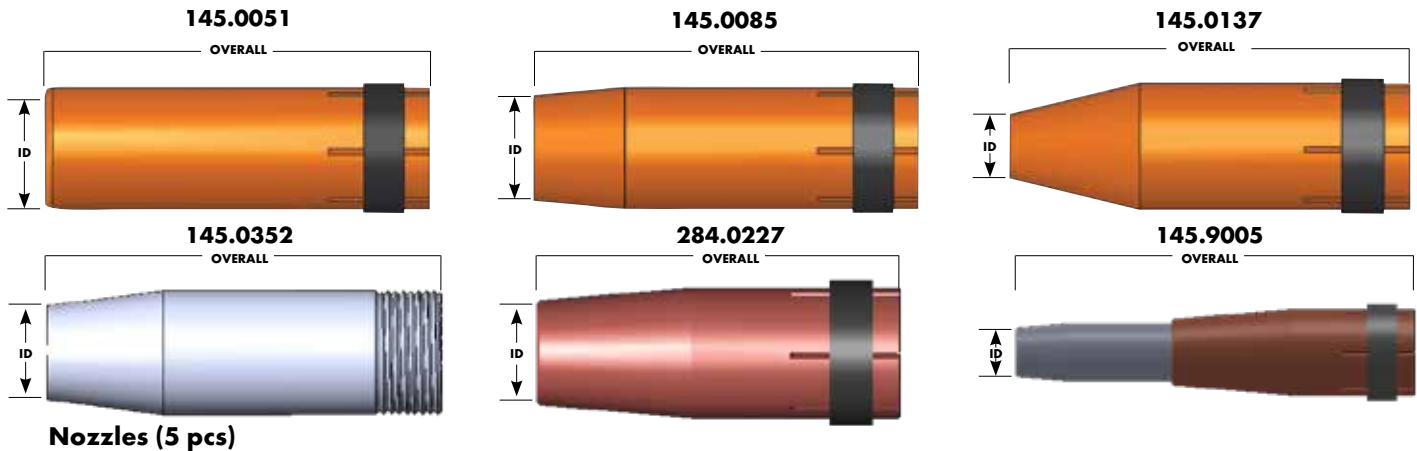

Nozzles (5 pcs)

Description	ID	ID	OD	OD	Length	Length	Part No.
	IN	MM	IN	MM	IN	MM	
Nozzle Cylindrical 501	13/16"	20mm	15/16"	24mm	3"	76mm	145.0051
Nozzle Conical STD 501	5/8"	16mm	15/16"	24mm	3"	76mm	145.0085
Nozzle Conical Small 501	9/16"	14mm	15/16"	24mm	3"	76mm	145.0132
Nozzle Conical HD 501	5/8"	16mm	15/16"	24mm	3"	76mm	145.0086
Nozzle Bottleform 501	5/8"	16mm	15/16"	24mm	3"	76mm	145.0148
Nozzle Conical Small 501	3/8"	10mm	15/16"	24mm	3"	76mm	145.0137
Nozzle Conical Small 501	7/16"	11mm	15/16"	24mm	3"	76mm	145.0139
Nozzle Spot Weld	13/16"	20mm	15/16"	24mm	13/8"	85mm	145.0179
Nozzle Narrow Gap(Front)	3/8"	9mm	5/8"	16mm	2"	51mm	145.0352
Nozzle Narrow Gap(Base)	3/5"	14.7mm	15/16"	24mm	2 3/4"	67mm	284.0227
Nozzle Narrow Gap(Complete)	3/8"	9mm	15/16"	24mm	4"	110mm	145.9005

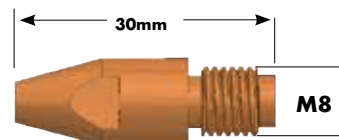
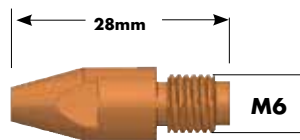

Optional, contact ABICOR Binzel.

Contact Tips (25 pcs)

Style	Metric	Inch	M6 (069)	M8 (262)
			Part No.	Part No.
CU Copper, Standard	0.9	.035	140.0169	140.0214
CU Copper, Standard	1.0	.040	140.0242	140.0313
CU Copper, Standard	1.2	.045	140.0379	140.0442
CU Copper, Standard	1.4	.052	140.0516	140.0533
CU Copper, Standard	1.6	.062	140.0555	140.0587
CU Copper, Standard	2.0	.078	140.0646	140.0653
CU Copper, Standard	2.4	.094	—	140.0677
CZ Copper Zirconium, Optional	0.9	.035	140.0172	140.0217
CZ Copper Zirconium, Optional	1.0	.040	140.0245	140.0316
CZ Copper Zirconium, Optional	1.2	.045	140.0382	140.0445
CZ Copper Zirconium, Optional	1.4	.052	140.0519	140.0536
CZ Copper Zirconium, Optional	1.6	.062	140.0558	140.0590
CZ Copper Zirconium, Optional	2.0	.078	140.0648	140.0656
CZ Copper Zirconium, Optional	2.4	.094	—	140.0679
AL 262 for Aluminum	0.9	.035	141.0004	141.0043
AL 262 for Aluminum	1.0	.040	141.0006	141.0008
AL 262 for Aluminum	1.2	.045	141.0082	141.0075
AL 262 for Aluminum	1.4	.052	141.0019	141.0055
AL 262 for Aluminum	1.6	.062	141.0020	141.0022
AL 262 for Aluminum	2.0	.078	—	141.0033
AL 262 for Aluminum	2.4	.094	—	141.0035
Not Shown Contact Tip Wrench			191.0001	191.0001

Listed are popular tight tolerance tips. Contact Customer Service or your local Abicor Binzel Sales Representative for further information.

MB 501D Series Water-Cooled MIG Guns

Consumables: Liners

122.9007



Liners for Steel Wires

Part No.

Liner Steel 17' 035"-045"	122.9007
Liner Steel 17' 052"-062"	122.9058
Liner Steel 17' 078"-094"	122.9023
Liner Steel 28' 035"-045"	122.9012
Liner Steel 28' 052"-062"	122.9015

127.9001



128.9002



Liners for Stainless Wires

Specifications

Part No.

Liner C-TFE 035"-045" 12'	for 10' gun	127.9001
Liner C-TFE 035"-045" 14'	for 12' gun	127.9002
Liner C-TFE 035"-045" 17'	for 15' gun	127.9003
Liner C-TFE 052"-062" 12'	for 10' gun	127.9004
Liner C-TFE 052"-062" 14'	for 12' gun	127.9005
Liner C-TFE 052"-062" 17'	for 15' gun	127.9006
Liner PA 035"-045" 12'	for 10' gun	128.9002
Liner PA 035"-045" 14'	for 12' gun	128.9003
Liner PA 035"-045" 17'	for 15' gun	128.9004
Liner PA 045"-052" 12'	for 10' gun	128.9005
Liner PA 045"-052" 14'	for 12' gun	128.9006
Liner PA 045"-052" 17'	for 15' gun	128.9007
Liner PA 062"-078" 12'	for 10' gun	128.9008
Liner PA 062"-078" 14'	for 12' gun	128.9009
Liner PA 062"-078" 17'	for 15' gun	128.9010

126.9004



Liners for Aluminum

Specifications

Part No.

Liner C-TFE RD 035"-045" 12'	for 10' gun	126.9004
Liner C-TFE RD 035"-045" 14'	for 12' gun	126.9005
Liner C-TFE RD 035"-045" 17'	for 15' gun	126.9006
Liner C-TFE YW 052"-062" 12'	for 10' gun	126.9007
Liner C-TFE YW 052"-062" 14'	for 12' gun	126.9008
Liner C-TFE YW 052"-062" 17'	for 15' gun	126.9009
Collet Plastic Liner 024"-045"	10 pcs.	131.0001
Collet Plastic Liner 052"-078"	10 pcs.	131.0002
O-Ring 3.5X1.5mm	10 pcs.	165.0008
Liner Support (for plastic liners) Specify Feeder		129.XXXX
Contact Tip Wrench		191.0001

Handles and Parts

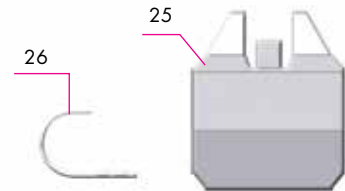
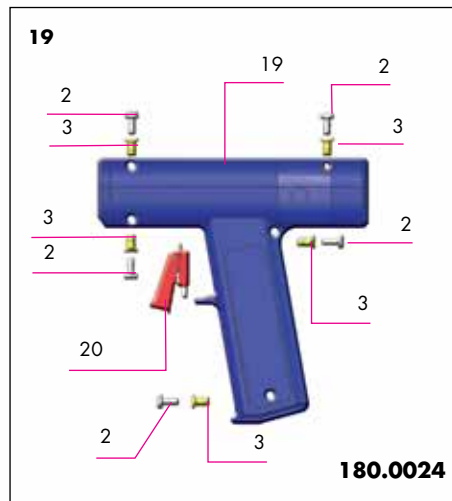
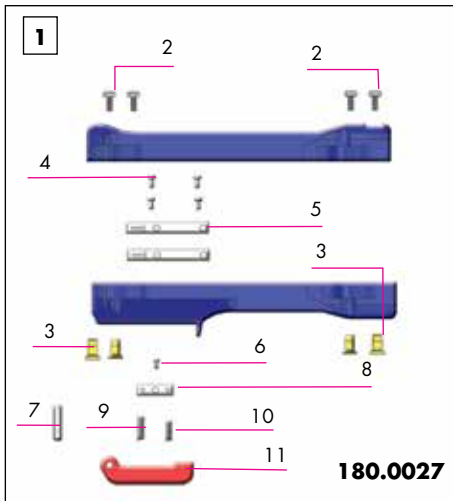
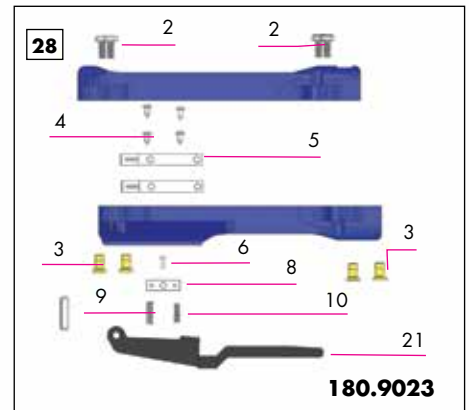
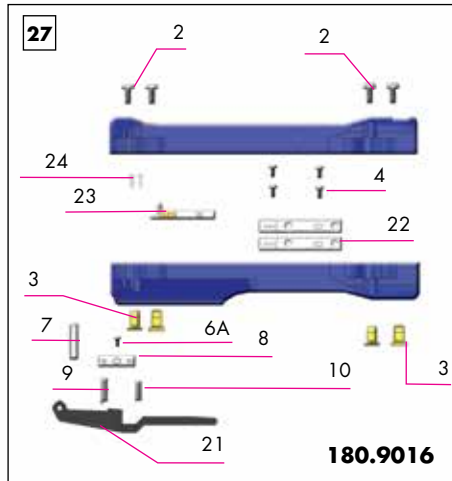
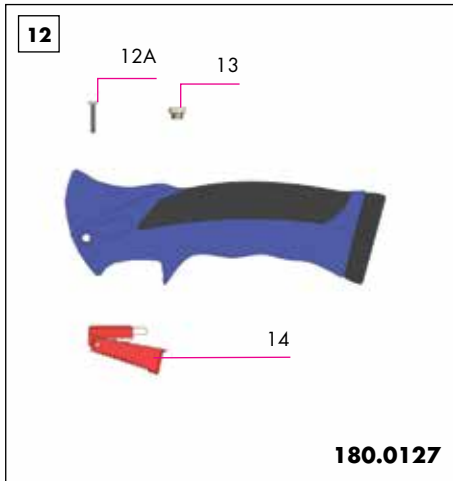

MB/MP 501D Handles

Item No.	Description	Part No.	Item No.	Description	Part No.
1	Handle Easy Grip Standard	180.0027	19	Handle Pistol Grip	180.0024
2	Screw Slotted Head	000.0554	20	Switch Trigger STD	185.0005
3	Nut Insertion M4x10	400.0095	21	Trigger Extended Easy Grip Sm	400.0166
4	Screw Sheet Metal M3x9.5	400.0199	22	Blade Trigger Long DS	400.9044
5	Blade Trigger Long	400.0039	23	Contact Strip	185.9029
6	Screw Slotted Shoulder M3x12	400.0036	24	3/8" Panhead Sheet Metal Screw	185.9030
6A	Screw Slotted Shoulder M3x12 F/DS	284.0218	25	Heat Shield STD use w/1, 27, 28	181.0002
7	Pin Trigger 4x20mm	000.0217	25	Heat Shield Ergonomic use w/12	181.0005
8	Blade Trigger Center	400.0038	25	Heat Shield Pistol Grip use w/19	181.0006
9	Spring Pressure Trigger Large	400.0037	26	Gun Hanger Easy Grip Handle	400.0155
10	Spring Trigger Small	400.0056	27	Handle Easy Grip Sm DST	180.9016
11	Trigger Easy Grip Small	400.0032	28	Handle Easy Grip Sm ET	180.9023
12	Handle Ergonomic	180.0127			
12A	Screw Pan Head Ergo Handle	400.1091			
13	Nut M4	400.1123			
14	Switch Trigger Ergonomic	185.0101			

MB 501D Series Water-Cooled MIG Guns

Parts List, Body-Cable Assembly

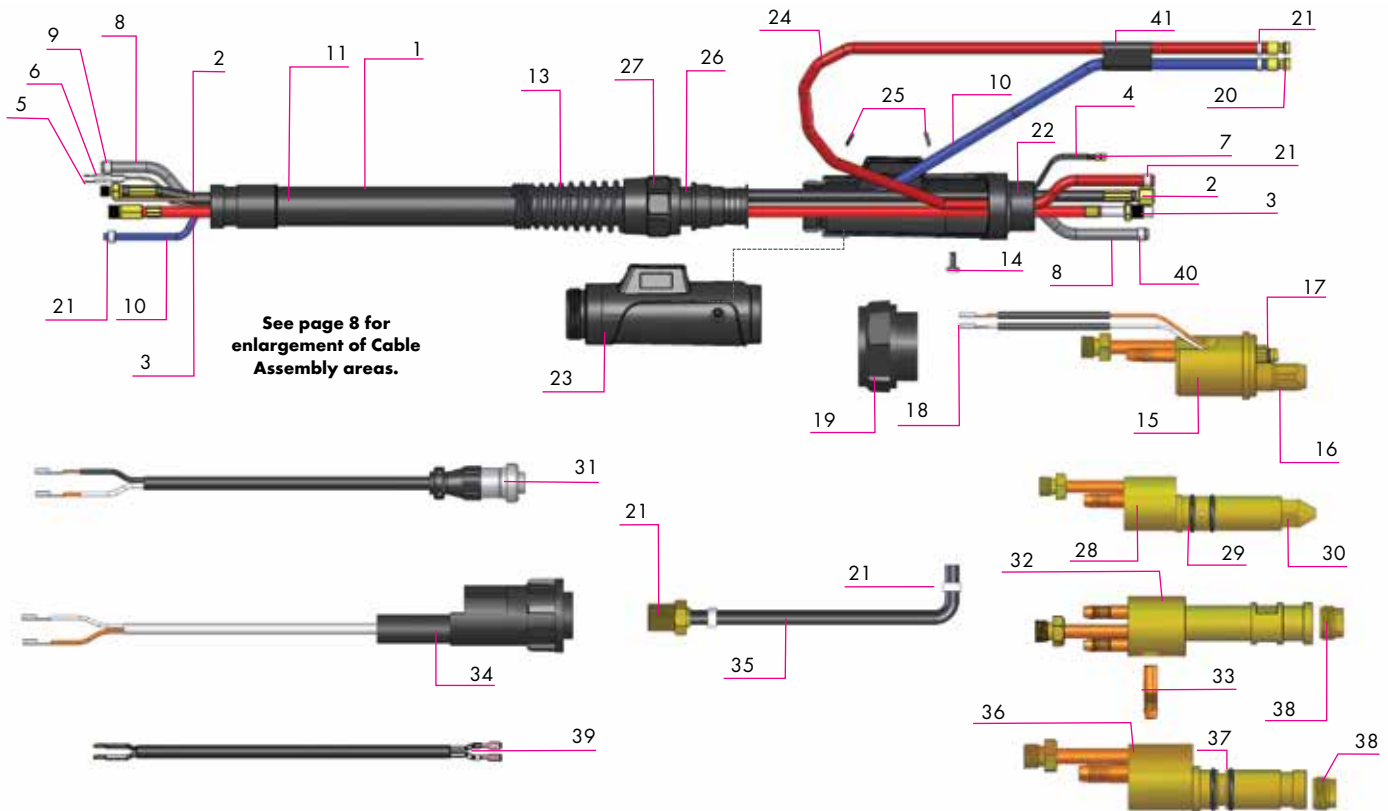

MB 501D Body Cable Assembly

Item No.	Description	Part No.	Item No.	Description	Part No.
1	Cable Assembly 10'	022.0034	13	Support Cable Spring Short	500.0235
1	Cable Assembly 10' F/ERGO	022.9083.US	14	Screw Slotted Head M4x6	000.0552
1	Cable Assembly 12'	022.0036	15	Block Adapter Central Rear w/c	501.0015
1	Cable Assembly 12' F/ERGO	022.9084.US	16	Nut Liner retaining M10x1	501.0082
1	Cable Assembly 15'	022.0040	17	O-Ring 4.6x1.07mm	165.0002
1	Cable Assembly 15' F/ERGO	022.9085.US	18	Connector Female Trigger	175.0003
2	Power Cable 10' MB 240/501	115.0065	19	Nut Adapter	500.0213
2	Power Cable 12' MB 240/501	115.0068	20	Fitting Water Male	501.0114
2	Power Cable 15' MB 240/501	115.0072	21	Clamp Hose w/bridge 9.5mm	171.9001
3	Conduit 10' MB 240/501	156.0019	22	Support Bottom Round HD	500.0415
3	Conduit 12' MB 240/501	156.0021	23	Support Top Round HD	500.0416
3	Conduit 15' MB 240/501	156.0025	24	Water Hose Red 5x8mm	103.0082
4	Wire 2 Conductor Trigger bulk	100.0019	25	Hole Plug F/500.0415 & 500.0416	500.0431
5	Connector Female Spade Trigger	175.0022	26	Ring Clamp Inner	400.0328
6	Insulator Connector	400.0119	27	Ring Clamp Outer	400.0329
7	Connector Male Trigger	175.0004	28	Adapter Assembly MR	272.9005
8	Hose Gas Black 4.9x7.9mm	109.0040	29	O-Ring 13.46x2.08mm	165.9006
9	Clamp Hose 8.7mm	171.0002	30	Liner Nut MR	272.9007
10	Hose Water Blue 5x8mm BJK (Sold per Meter)	103.0002	31	Plug Amp Miller	175.9122
10	Hose Water 10' cpl Blue includes items 20,21	103.0034	32	Adapter Assembly LN Ext Gas	501.9333
10	Hose Water 12' cpl Blue includes items 20,21	103.9001	33	Gas Fitting LN Ext Gas	353.0002
10	Hose Water 15' cpl Blue includes items 20, 21	103.9002	34	Plug Amp Head Lincoln 2-pin/male	175.9103
11	Cover Cable outer 10' complete	107.0035	35	Gas Hose Assembly LN	102.9149
11	Cover Cable outer 10' complete F/ERGO	107.9125.US	36	Adapter Assembly Tweco Direct	272.9014
11	Cover Cable outer 12' complete	107.0040	37	O-Ring 127x1.78	165.0025
11	Cover Cable outer 12' complete F/ERGO	107.9126.US	38	Liner Nut HT/LN	331.9002
11	Cover Cable outer 15' complete	107.0047	39	Wire Assembly CPL w/Faston Conn	175.9024
11	Cover Cable outer 15' complete F/ERGO	107.9127.US	40	Clamp Hose 9.5mm	171.0003
11	Cover Cable outer 25x28mm bulk	107.0004	41	Tube Shrink	000.9120.US

Body Cable Assembly Enlargements

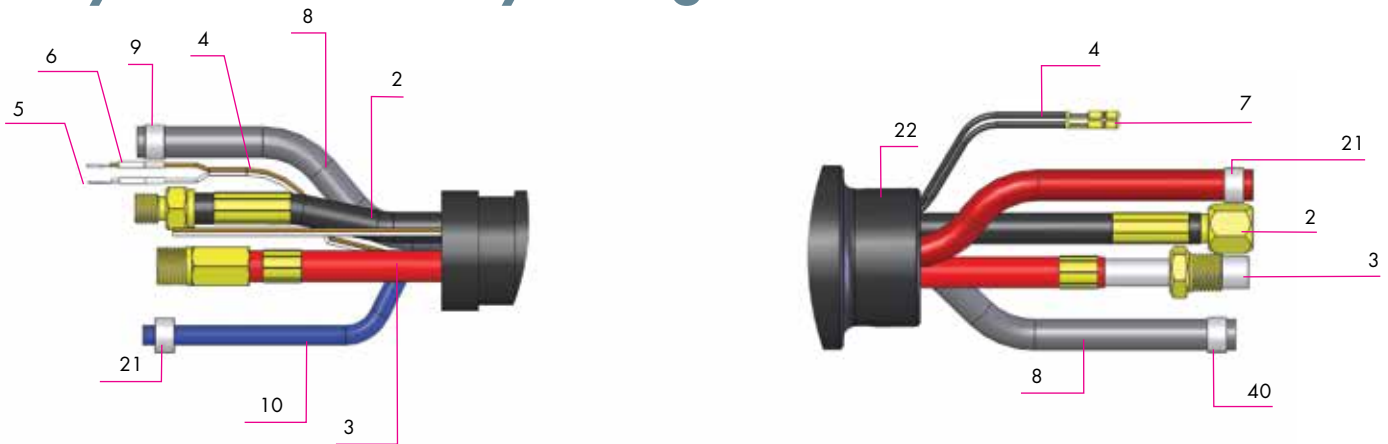

MB 501D Body Cable Assembly (Enlarged)

Item No.	Description	Part No.	Item No.	Description	Part No.
2	Power Cable 10' MB 240/501	115.0065	6	Insulator Connector	400.0119
2	Power Cable 12' MB 240/501	115.0068	7	Connector Male Trigger	175.0004
2	Power Cable 15' MB 240/501	115.0072	8	Hose Gas Black 4.9x7.9mm	109.0040
3	Conduit 10' MB 240/501	156.0019	9	Clamp Hose 8.7mm	171.0002
3	Conduit 12' MB 240/501	156.0021	10	Hose Water Blue 5x8mm BJK	103.0002
3	Conduit 15' MB 240/501	156.0025	21	Clamp Hose w/bridge 9.5mm	171.9001
4	Wire 2 Conductor Trigger bulk	100.0019	22	Support Bottom Round HD	500.0415
5	Connector Female Spade Trigger	175.0022	40	Clamp Hose 9.5mm	171.0003



WARNING

Read and follow the manufacturer's instructions, employer's safety practices, and Material Safety Data Sheets (MSDSs). Only qualified personnel should install, use, or service this material and/or equipment



WELDING SPARKS can cause fire or explosion

- Do not weld near flammable material • Do not weld on closed containers. • Remove combustibles from the work area and/or provide a fire watch. • Avoid oily or greasy clothing as a spark may ignite them.



ARC RAYS can injure eyes and burn skin

- Always wear correct eye, ear, and body protection. • Always wear a welding helmet with the proper grade filter lens. Protect yourself and others from spatter arc flash rays by using protective screens, barriers and welding curtains.
- Always wear protective gloves and clothing to cover exposed skin. This will aid in the prevention of arc and spatter burns.



ELECTRIC SHOCK can kill.

- Always wear dry installing gloves. • Do not touch live electrical parts. • Always disconnect power source before hooking up or changing electrodes, nozzles and other parts.



FUMES AND GASES can be hazardous to your health.

- Keep your head out of the fumes. • Use enough ventilation or exhaust at the arc to keep fumes and gases from your breathing zone, and general area. • Fumes from cutting and welding can deplete air quality, causing injury or death. Always wear an air supplied respirator in confined areas, or if breathing air is not safe.



LOUD NOISE can damage hearing.

- Always wear protective hearing devices to ensure protection when noise levels exceed OSHA standards.

ABICOR BINZEL USA, Inc.
650 Medimmune Ct., Suite 110, Frederick, MD 21703-8619
Tel: 301.846.4196 Fax: 301.846.4497 www.binzel-abicor.com

Read American National Standard Z49.1, "Safety in Welding, and Cutting, and Allied Processes," available from American Welding Society, 550 N.W. LeJeune Rd., Miami, FL 33126; OSHA Safety and Health Standards, available from U.S. Government Printing Office, Washington, DC 20402.

ID 123-4567CI



BINZEL, S.A. DE C.V.
Municipio de Pabellon de Arteaga 102
Valle de Aguascalientes, 20358
San Francisco de los Romo, Ags. MX
Tel: +52(499) 9730133
Fax: +52(449) 9731388
info@binzel.com.mx



ABICOR BINZEL USA
650 Medimmune Ct., Suite 110
Frederick, MD 21703-8619
Tel: 301.846.4196
Fax: 301.846.4497
customerservice@abicorusa.com

www.binzel-abicor.com